

# THE INFLUENCE OF WIND, AND WINDAGE ALLOWANCE

We all know that the wind will blow our lightweight pellets off course. The trick is in trying to estimate how much the shot will deviate from a straight line, and making the necessary allowance.

What are the factors that affect the pellet? These are the most significant.

1. Wind speed
2. Wind direction
3. Time of flight, which depends on:
  - a. Muzzle velocity
  - b. Shape of the pellet
4. Barrel

## 1. Wind Speed

All other things being equal, the amount the wind blows the pellet off course is directly proportional to wind speed. That is to say, twice the wind speed means twice the deflection.

How to estimate wind speed? The usual indicators are, how the grass is being blown, how the leaves on the trees are moving, any smoke trails are useful, how much the target cords are being blown. On a cold damp day, see where your breath goes when you breathe out. On a warm sunny day, through your scope you may see some heat haze, and this will ripple and flow to show you what the wind is doing.

A useful tip is to toss some strands of grass into the air and watch the angle they fall to the ground at. If you can estimate this angle, and most people can guess 45° or thereabouts, then in your head divide the number of degrees by four and that is roughly the wind speed in miles per hour.

With a little bit of practice you can learn to estimate wind speed. Stand with your back to the wind, and walk forwards at a reasonably brisk pace. For most people this is about 4mph. If you can still feel the wind on your back then it is blowing at more than 4mph. On the other hand, if it now feels in your face, you are walking faster than the wind.

## 2. Wind direction

The same kind of observation will give you an idea of the wind direction, too. You need to think of the wind direction in terms of a clock face, 12 o'clock being directly in your face, 6 o'clock being directly behind you, and 3 and 9 o'clock being directly side on. The other points of the clock, 1, 2, 4, 5 etc are VERY important as well.

A direct on head wind or tail wind has almost no effect on the pellet so with reasonable accuracy they can be ignored, except for long range targets. They do come into play if you are shooting uphill or downhill, when the wind can lift the pellet if it gets underneath, or push it down especially on downhill shots.

A broadside wind has the most effect, which is what we would expect.

VERY IMPORTANT, but hard to believe: a wind from 1 o'clock, 5 o'clock, 7 o'clock or 11 o'clock has HALF the effect of the broadside wind. So the wind doesn't have to be much off head on or directly behind before it has a big effect.

A wind from 2, 4, 8 and 10 o'clock has MORE THAN THREE QUARTERS the effect of a broadside. For the technically minded, and those good at maths, the effect depends on the sine of the angle. 1 o'clock is at 30 degrees to head on, and  $\sin 30$  is 0.5 (a half). 2 o'clock is at 60 degrees to head on, and  $\sin 60$  is 0.866 (more than 0.75, three quarters). In practice until you are very expert at reading the wind, you can treat a wind from 2,4, 8, or 10 o'clock as NEEDING the same allowance for drift as a broadside wind. Judging the angle to this amount of precision is just as hard as estimating the wind speed.

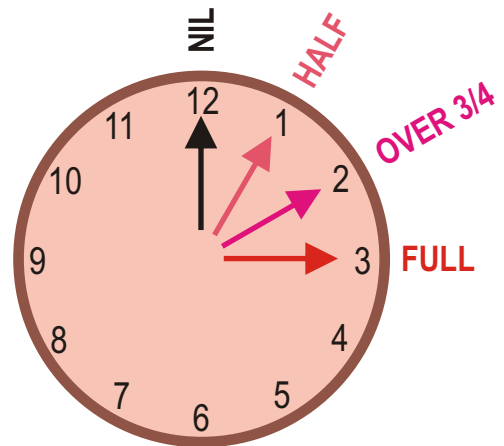

### 3. Time of flight

Longer range targets need more wind allowance because the pellet takes longer to get there, and the more time the pellet is exposed to the wind the more it will drift. Also, remember that the pellet very rapidly slows down as soon as it has left the barrel, so it takes a lot longer to travel the second half of the journey to the target than the first. A target 50 yards away takes more than twice the time to reach compared to one at 25 yards. What this means is, all things being equal, a target twice as far away doesn't need twice the wind allowance, it needs roughly FOUR TIMES as much. Again in technical parlance, the drift varies (approximately) as the square of the distance.

Look at this table; it shows the relative amount of drift at various distances. Assuming a base level of 50 yards, a target just 5 yards further away will see 1.2 times as much wind drift. Similarly, a target 30 yards away, more than half the distance, has only about a third of the drift.

Range in yards	Relative drift factor
10	0.04
20	0.15
30	0.35
40	0.63
50	1.0
55	1.2

### Muzzle velocity

A lot of shooters struggle to set their rifles up as close to the legal limit as they can, in the belief that a faster pellet will get to the target in less time and be affected less by the wind. In theory, this is true. In practice, unless your gun is seriously underpowered, it makes not a lot of difference. Many pellets have a maximum permitted velocity of about 800 feet per second to keep under 12 foot pounds, and most FT guns will be shooting at somewhere between 760 and 790 fps. A 10 mph wind at 15 degrees (half way between 11 and 12 o'clock) on a 55 yard target will want about 1.6 inches of allowance at 790 fps. At 760 fps this increases to 1.7 inches, a difference of half a pellet diameter. No-one can estimate the wind speed and direction with that accuracy. Remember, the direction is very critical. If it was a 20 degree wind, not 15 degrees, it would need another half an inch. So don't worry about muzzle velocity, in practical terms it's not the biggest factor.

## Shape of the pellet

The type of pellet can make a big difference, it's down to the ballistic coefficient which is a measure of the drag, and how quickly the pellet slows. Most FT and HFT shooters these days shoot pellets that are very similar in shape and geometry so again in reality this is a small factor. You will want to concentrate on using one type of pellet so that you know its trajectory, so how it behaves in the wind just falls into place at the same time.

## 4. Barrel

Uncannily, the same make of pellet shot from apparently identical guns under identical conditions can demand different windage allowances. Why this should be so is a matter of much discussion, with many theories. Some believe that the pellet's shape is altered by the process of being launched out of the barrel, and what starts out as a standard design is customised one way by one barrel, and differently by another.

There are some makes of pellet that seem to work well in some guns and appallingly in others. I've found that most of my pre-charged guns perform better with a pellet that is not tight in the breech; I get more consistent results if the pellet enters the breech with little or no resistance.

## Notes:

The deflection of the pellet is not just a left-right thing. Theory says there is also an up-down dimension too. The spinning pellet (clockwise when seen from behind in almost all barrels) tries to climb up over a wind from the right, blowing left. So when you aim off to the right a bit to allow for the side wind, you must also remember that this same wind is going to make the pellet go a bit high. Your point of aim then needs to be nearer 4 o'clock than 3 o'clock. Similarly a wind from the left pushing pellets to the right tends also to press them down, so allow a little more elevation, like aim at 10 o'clock.

Try to think in terms of an actual distance to aim off, rather than see that distance as "numbers of kill zones", or numbers of mildots. Often I hear a shooter say, "I had to give that one three mildots." But unless you know what magnification he was shooting at, and some more information about his scope, it's not very helpful.

A standard kill zone is 40mm across. Even if the drift you are going to allow is about 40mm, then see it as 40mm, not as one kill zone. When you are faced with a reducer target, it is very easy not to give enough if you are used to thinking just in terms of kill zones. Aiming off 20mm on a full size kill zone means placing the crosshairs on the edge of the kill zone. Aiming off 20mm on a 1 inch reducer means you are well outside the kill zone.

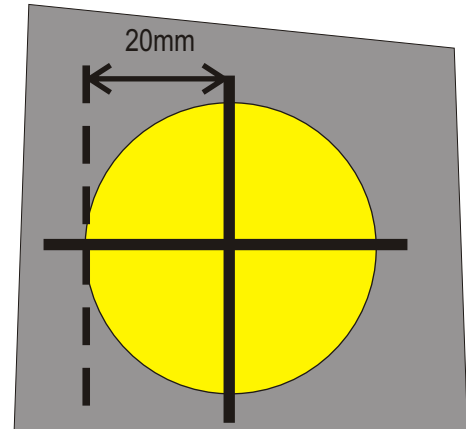

standard 40 kill zone

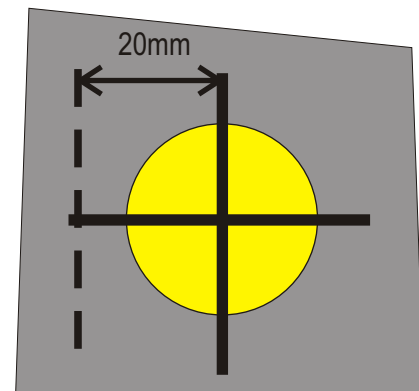

25 (1 inch) kill zone

Finally, let's look at a worked example.

As a rough guide, a wind of 1 mph blowing broadside will cause a pellet - from a 177 air rifle with a power level close to the limit - to drift about 0.5 inch at 50 yards. It needs some mental arithmetic but you can calculate some useful pointers from that.

Example: Estimated 10 mph wind blowing at 30 degrees. Target distance 40 yards.

If we allow 0.5 inch per every mph, then it would be 10 times that for 10mph = 5 inches.

But that is for a broadside wind. In this case allow for 30 degrees. Factor for 30 degrees = 1/2. (See section 2). Say 2 1/2 inches.

Now allow for range being only 40 yards, not 50 (this is trickier). 40 yard range factor = 0.63 (See section 3). Multiply by 0.63.

2.5 X 0.63 = 1.5 (near enough). Allow 1 1/2 inches windage.

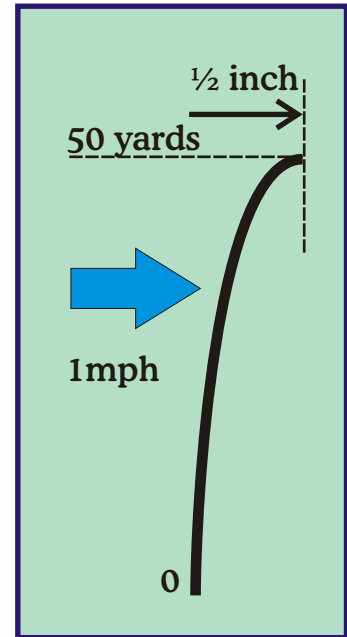

Remember, it is very difficult to get both the wind speed and the wind direction judged spot on, so don't get too hung up about mathematical precision and taking a calculator onto the range. This is just meant as a guide to help you understand how the different factors influence where the pellet finally hits - or misses! - the target. The rest has to come from experience.

Rich Clark, February 2011

pellet BC		0.0220
wind speed	mph	1
muzzle velocity	fps	792
target distance	yards	50
angle to wind	degrees	90
trim factor		1.0

1.0 is the theoretically correct value. ONLY change it if you find from experience that your rifle and pellet need more or less allowance

vac. flight time	secs	0.189
actual flight time	secs	0.219
drift	inches	0.5
	mm	13

scope mag	X	10
mildots to allow		0.3

If you are able to work with Excel spreadsheets on your PC then download the wind drift calculator from the **USEFUL STUFF** page on this website. You'll be able to experiment graphically in the warm and dry so that you are well-prepared for a shoot in a breeze.